

27-Line SCSI Source/Sink Regulator

FEATURES

- Complies with SCSI, SCSI-2, SCSI-3 SPI and Fast-20
- 2.85V Regulated Output Voltage With 2% Tolerance
- Provides Current for up to 27 Lines of Active Termination for SCSI Buses
- -750mA Sourcing Current for Termination
- +300mA Sinking Current for Active Negation
- 1.0V Dropout Voltage Regulator at 750mA and 2.75V Output
- 100 μ A Supply Current in Disconnect Mode
- Current Limit and Thermal Shutdown Protection
- Low Thermal Resistance Surface Mount Packages

DESCRIPTION

The UC560 provides current for up to 27 lines of active termination for a SCSI (Small Computers Systems Interface) parallel bus. The SCSI standard requires active termination at both ends of the cable. The UC560 is based on the UC5603 and UC5613 SCSI Active Terminators. It uses the voltage regulator and internal logic circuits of those parts, but has no termination circuits. The UC560 provides greater source current drive capability compared to the UC5603 and UC5613.

The UC560 sink current maintains regulation with all active-negation drivers negated. It provides a disconnect feature which disables the regulator to greatly reduce standby power. Internal circuit trimming is utilized for a 2% tolerance output voltage. Other features include thermal shutdown and current limit for short circuit conditions.

The UC560 is available in low thermal resistance versions of the industry standard 8-pin power SOIC, 5-pin TO-220 and 5-pin TO-263.

BLOCK DIAGRAM

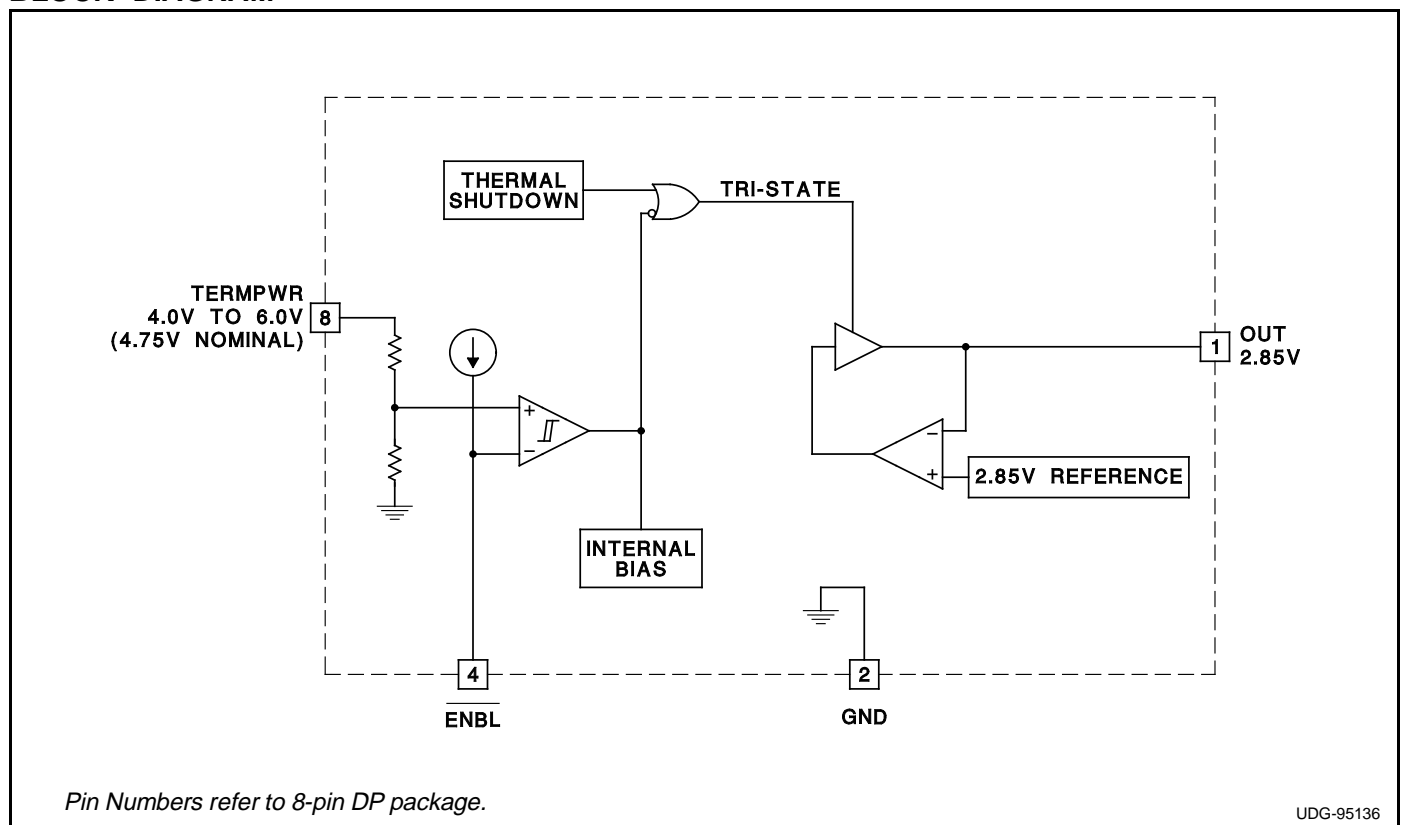

UDG-95136

ABSOLUTE MAXIMUM RATINGS

TERMPWR Voltage 7V
 ENBL Voltage -0.3V to TERMPWR + 0.3V
 Regulator Output Current 1.1A
 Power Dissipation 2.5W
 Storage Temperature -65°C to +150°C
 Junction Temperature -55°C to +150°C
 Lead Temperature (Soldering, 10 sec.) +300°C
Currents are positive into, negative out of the specified terminal. Consult Packaging Section of Databook for thermal limitations and considerations of packages.

RECOMMENDED OPERATING CONDITIONS

TERMPWR Voltage 4.0V to 6.0V
 ENBL Voltage 0V to 5V

CONNECTION DIAGRAMS

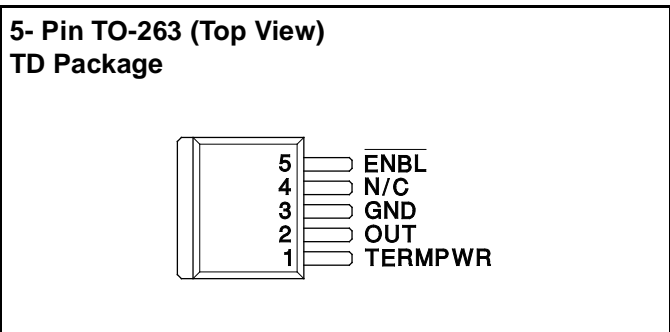
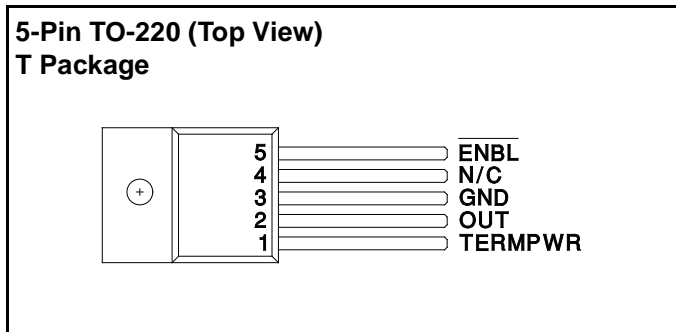
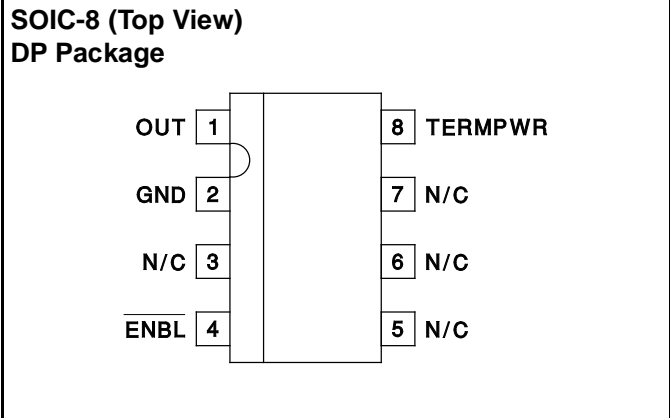

ELECTRICAL CHARACTERISTICS Unless otherwise specified, TA = 0°C to 70°C, TERMPWR = 4.75V, ENBL = 0V, TA = TJ.

PARAMETER	TEST CONDITIONS	MIN	TYP	MAX	UNITS
Supply Current Section					
TERMPWR Supply Current	No Load		14	20	mA
	ILOAD = -700mA		725	875	mA
Power Down Mode	ENBL = 2.0V		100	150	µA
Regulator Section					
Regulator Output Voltage	25°C, No Load	2.8	2.85	2.9	V
Load Regulation	I _{REG} = 300mA to -750mA			100	mV
Line Regulation	TERMPWR = 4.0V to 6.0V, No Load			10	mV
Dropout Voltage	I _{OUT} = -750mA, V _{OUT} = 2.75V		1	1.2	V
Short Circuit Current	V _{REG} = 0.0V	-850	-1100		mA
Sinking Current	V _{REG} = 3.5V		400	500	mA
	ENBL = 2.0V, V _{REG} = 3.0V		1	2	mA
Thermal Shutdown	(Note 1)		170		°C
Thermal Shutdown Hysteresis	(Note 1)		10		°C
Shutdown Section					
ENBL Threshold		1.1	1.4	1.7	V
Threshold Hysteresis			100		mV
ENBL Output Current			10	15	µA

Note 1: Guaranteed by design. Not 100% tested in production.

PIN DESCRIPTIONS

ENBL: Enable Bar pin. The ENBL function is active low, and the pin will source 10μA typically when at ground and TERMPWR is between 4V and 6V. The part will go into disable mode if ENBL is above 1.4V typical, and will turn back on when ENBL drops below 1.3V typical. The part also greatly reduces TERMPWR current when disabled (100μA typical).

GND: Ground pin.

OUT: 2.85V regulated output voltage pin. The part is internally current limited for both sinking and sourcing

current to prevent damage. When the part is in disabled mode (ENBL ≥ 1.4V typical), the output goes to 0V with no external supply source on OUT. The part will sink current, though, if there is an external supply voltage applied to OUT when in disabled mode.

TERMPWR: Supply voltage pin. The pin should be decoupled with at least a 2.2μF low ESR capacitor. Lengths should be kept at a minimum.

APPLICATIONS INFORMATION

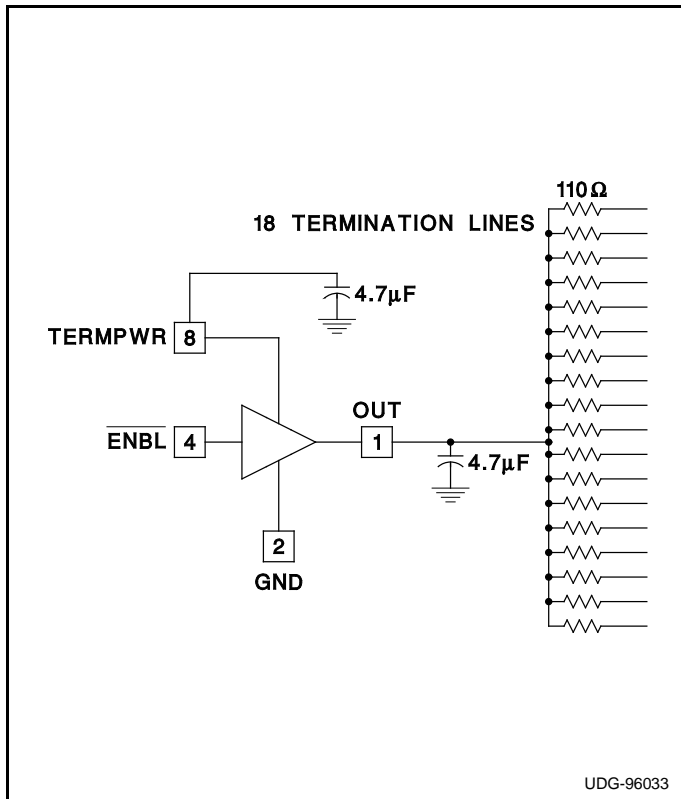

Figure 1. Typical SCSI Bus Configuration Utilizing UC560 Device

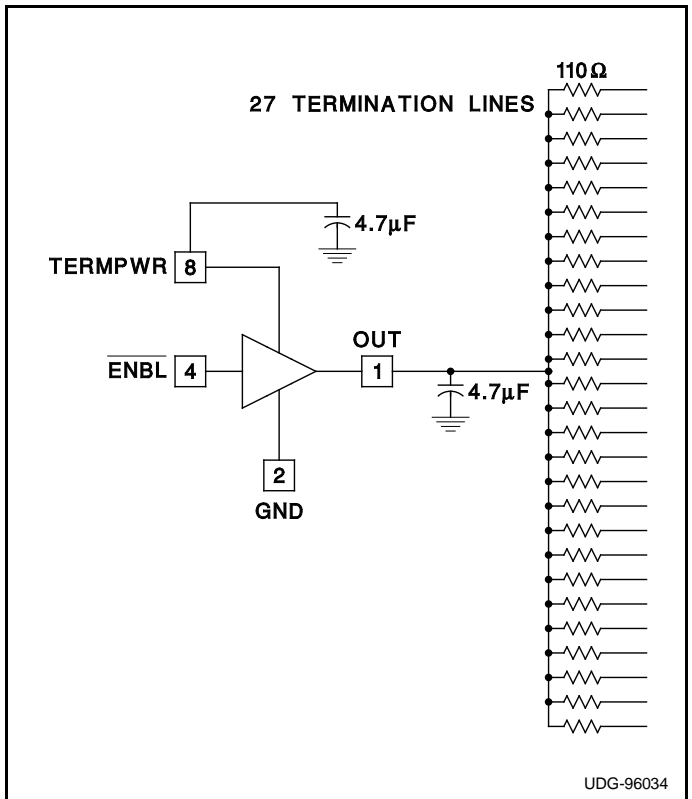

Figure 2. Typical Wide SCSI Bus Configuration Utilizing UC560 Device